

:300436

2016

A

— —

“ ”

1	A				
2					
	QFII			5	
			2		
3					
		1			
2					
4			700	700	
5				32,000	
25,750				80%	
	15,750		90%		9,000
	"	"			

序号	名称	金额	占营业收入的比例
10	其他	4.76%	
11	合计		
1	营业收入		
2	营业成本		
3	营业税金及附加		
4	销售费用		
5	管理费用		
6	财务费用		
7	资产减值损失		
8	公允价值变动损益		
9	其他		

A

“ ”

	" "

--	--

A

300436

2001 6 28

14,000

89

B

10

B

913500007297027606

0591-28378999

0591-28378833

350003

chenying@cosunter.com

www.cosunter.com

1

" "

30

" "

TATSUMOTO TSUYOSHI

2004

2000

TATSUMOTO TSUYOSHI

" "

TATSUMOTO TSUYOSHI

2

"

"

" "

" "

	2015		2016		2017
营业收入	2,400	3,750	4,688	5,659	7,324
净利润	25%		5		
经营活动产生的现金流量净额	3,000				
研发投入	3				
股权激励费用	-				
非经常性损益	-				
所得税费用	2015				99.76%

700

700

$$Q=Q_0 \cdot \left(\frac{P_0}{P}\right)^{\frac{1}{N}}$$
$$P = \frac{P_0 - \text{Div}}{1 + N}$$
$$P_0 = \text{Div} \cdot N$$

1

2

32,000

80%	25,750	25,750
	6,250	6,250
	32,000	32,000

24,750

90% " " 60%
 1 15,750 90%
 90% 10%
 2 3,000 " " 30% 6,000 "
 " " " 60% TATSUMOTO
 TSUYOSHI
 " TATSUMOTO TSUYOSHI
 40%

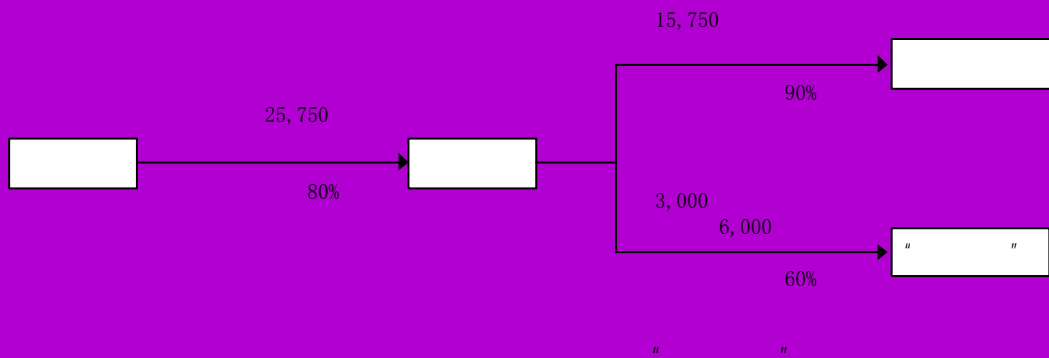

60% 8,400 14,700 57.14%

2016 4 7

"

"

2015 11 27

"

"

"

"

80%

32,000

80%	25,700	25,700
	6,300	6,300
	32,000	32,000

24,750

90% " " 60%
 1 15,750 90%
 90% 10%
 2 3,000 " " 30% 6,000 "
 " " " 60% TATSUMOTO
 TSUYOSHI " " 40%

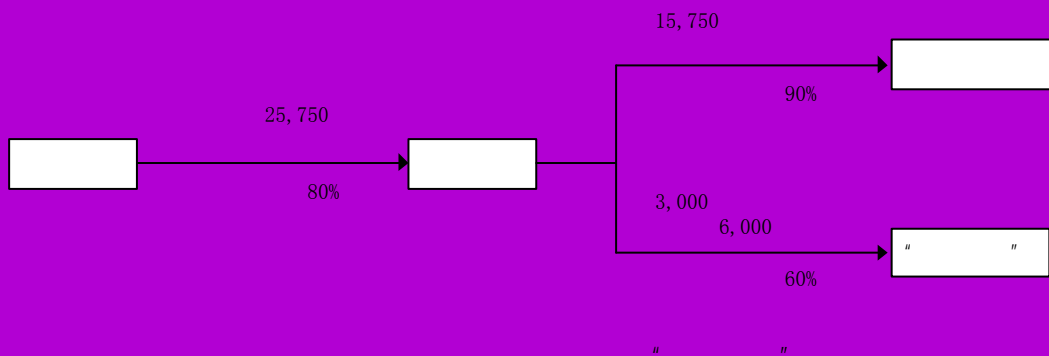

80%

1,000

NAKAZAWA SHOKO

2015 9 6

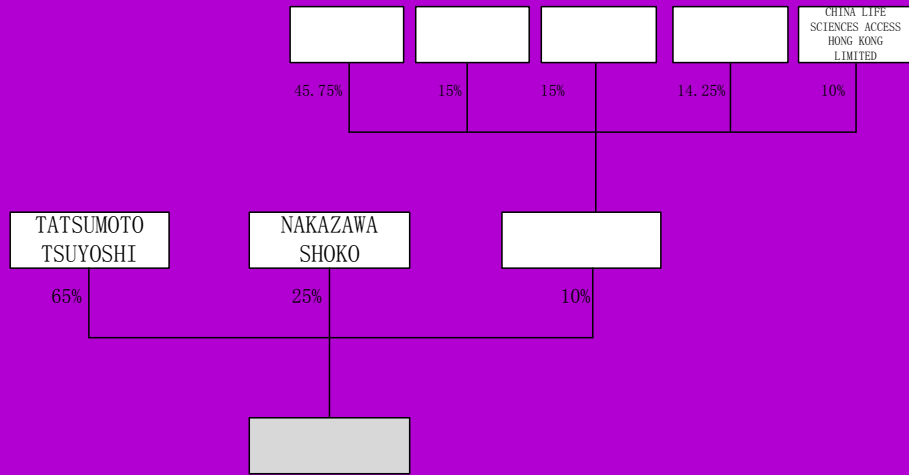

1

TATSUMOTO TSUYOSHI

NAKAZAWA SHOKO

2015 9 6

		%
	400	40%
TATSUMOTO TSUYOSHI	350	35%
NAKAZAWA SHOKO	250	25%
	1000	100%

2

2016 3 7

TATSUMOTO TSUYOSHI

30%

TATSUMOTO TSUYOSHI

%

	100	10%
TATSUMOTO TSUYOSHI	650	65%
NAKAZAWA SHOKO	250	25%
	1000	100%

1

2

3

2015 12 31

1.01

2015

	2015 12 31	2015
	137.16	
	1.01	
	136.15	
	0	
	-63.85	

2016 3 6

1

TATSUMOTO TSUYOSHI

NAKAZAWA SHOKO

2

TATSUMOTO TSUYOSHI

" "

3

" " 32,187.50

25,750

80%

15,750

90%

9,000

"

"

60%

1,000

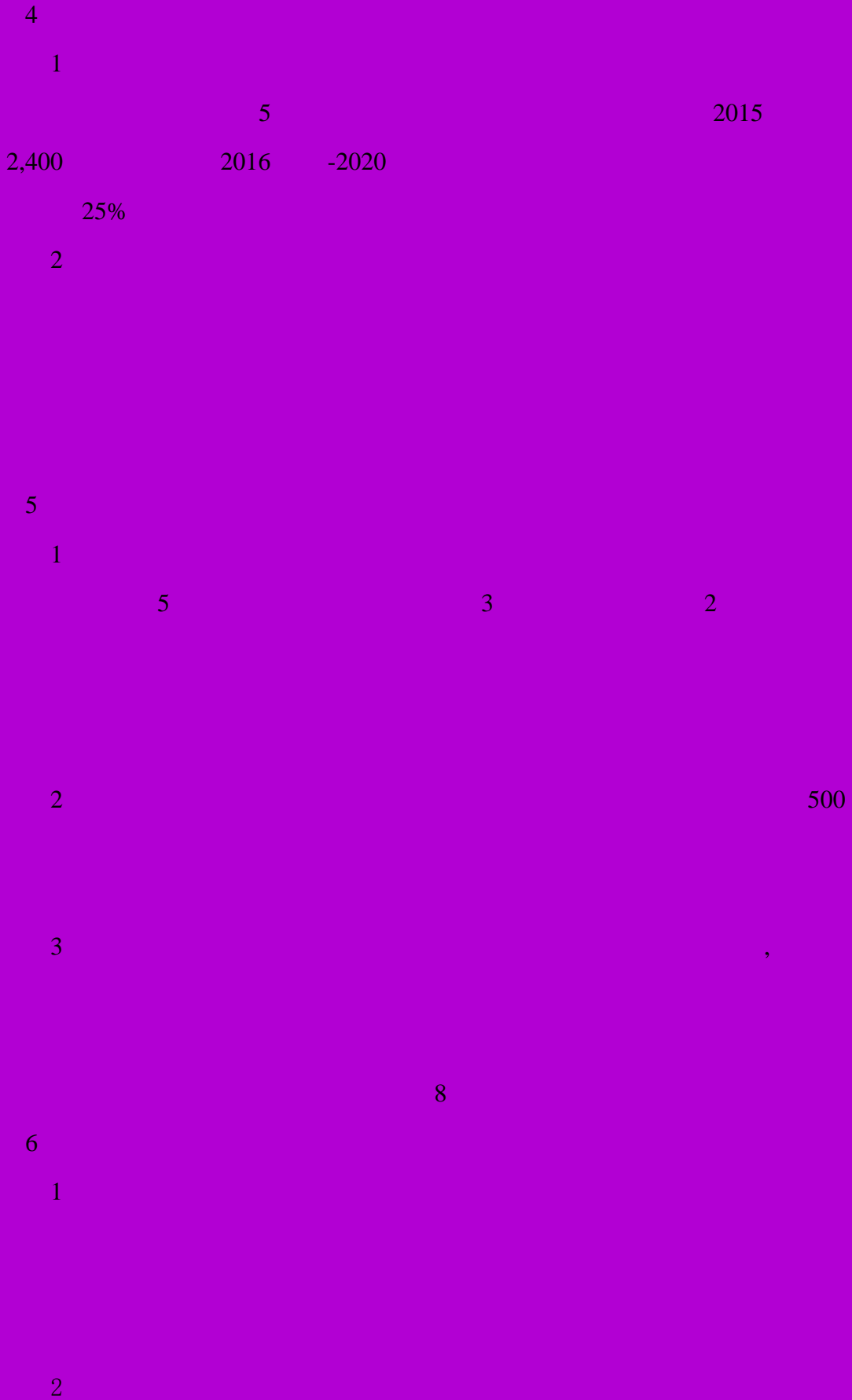

7

6

6

90%

350

1 2002 5
 2002 3 26 " "
 2002 4 19 2002
 C0007
 2002 4 19
 350 35 10% 315
 90%
 2002 5 15

	315.00	90.00%
	35.00	10.00%
	350.00	100.00%

2 2002 9
 2002 7 17

	315.00	90.00%
	35.00	10.00%
	350.00	100.00%

3 2002 12
 2002 12 12

	315.00	90.00%

	35.00	10.00%
	350.00	100.00%

1

1

100

2009 2 19

588 1

9131011568409801XG

2

1

2009 2 16

2009 2 17

2009 146

2009 2 19

	100.00	100.00%
	100.00	100.00%

2

2010 8 26

15% 34%

2010 8 26

2010 9 14

	51.00	51.00%
	34.00	34.00%
	15.00	15.00%
	100.00	100.00%

3

2015 10 23

15% 34%

2015 11 29

	100.00	100.00%
	100.00	100.00%

3

2

	2015 12 31	2014 12 31
	2015	2014
	220.69	224.97
	120.23	117.55
	100.46	107.42
	400.78	392.71
	32.11	33.81

2

1

600

2015 5 11

818

320681000341235

2

2015 5 11

3

2015 5

	2015 12 31
	2015
	563.59
	47.39
	516.19
	0
	-83.81

1

ISO 9001:2008 ISO 13485 2012 BRC
 14000 CE FDA



30

2

1

PE

			ZL201320574091.0
			ZL201420527744.4
			ZL201320254614.3

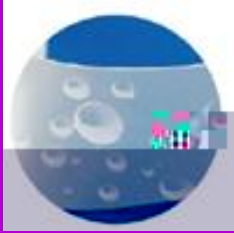
<p>PE</p>	 <p>均匀打孔，透气效果极佳，黏贴后透明无反光（见右手）</p>	<p>PE</p> <p>PE</p>	<p>PE</p> <p>PE</p> <p>ZL201320358300.8</p>
			<p>ZL201320673543.0</p> <p>ZL2011.2.0264240.4</p>
		<p>PE</p>	<p>ZL201120204096.5</p>

2

1

2

3

ZL201120201208.1

4

ZL201120201207.7

5

ZL201320763042.1

100-150

ZL201220193733.8



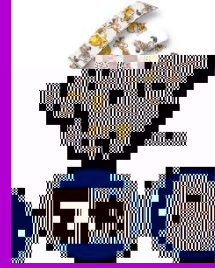

3

2.5cm× 5cm 10cm× 35cm



4

210

" " 2012-2014 "

5

3

150

5

30

"

2

"

5

1

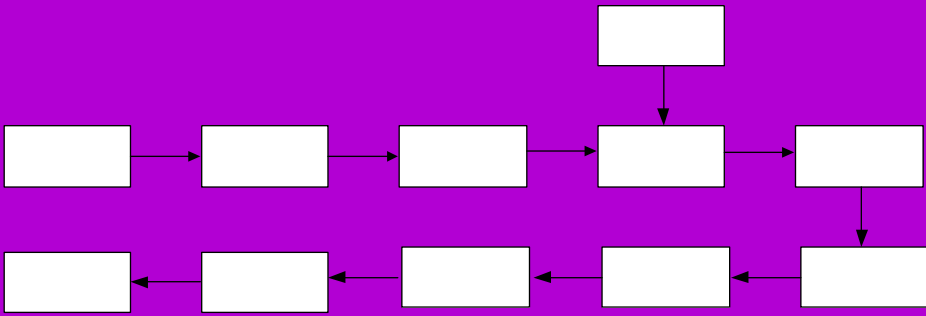

2

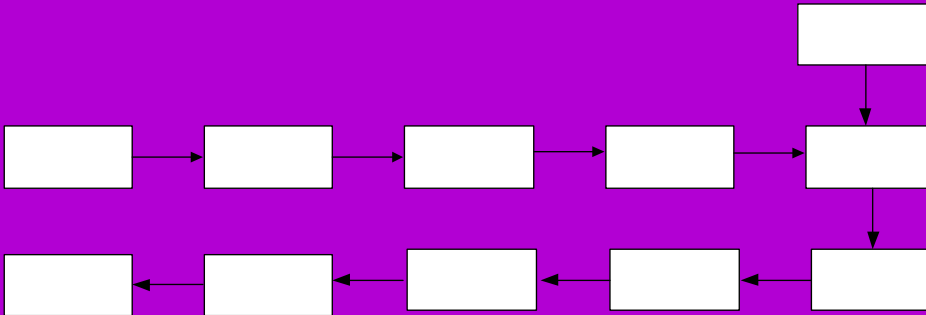

6

1

2

1

2

"

"

"

"

3

"

2				20140030	-
3				20160047	-
4				20160048	-
5				2012 2640626	2012.7.25- 2016.7.24
6				20142640045	2014.10.11- 2019.10.10
7				20152640281	2015.5.19- 2020.5.18
8				2012 2640689	2012.8.23- 2016.8.22
9				2012 2640627	2012.7.25- 2016.7.24
10				20162640227	2016.3.25-2 021.3.24
11	CE		TUV Rheinland LGA Products GmbH	DD601011080001	2015.8.6- 2017.4.25
12	FDA		FDA	3003844446	2014.11- 2019.10

5

6

2015 12 31

2,369.30

2015

	2015 12 31 2015	2014 12 31 2014
	11,454.52	11,241.40
	2,369.30	2,569.56
	9,085.22	8,671.84
	13,497.20	12,894.92
	2,161.72	1,507.56

2016 3 6

1

13

2

3

2015

2,000

1.75

90%

10%

4
 3
 2015 2,000
 15% 2016-2018 2,300 2,645
 3,042

5

6

6

6

" " 60%

" "

1 " "

TATSUMOTO TSUYOSHI

TATSUMOTO TSUYOSHI

" "

" "

" "

MD JANPAN

" MD"

" "

" "

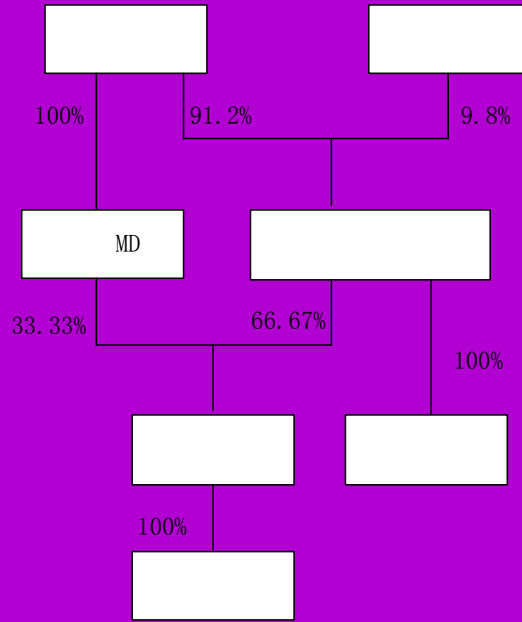

TATSUMOTO TSUYOSHI

TATSUMOTO TSUYOSHI

TATSUMOTO TSUYOSHI

2

1 MD

1

MD

MD

2014 10 21

2024 10 20

MD

2

1

2

3

COX

A

6

2007

”

0A

.....

”

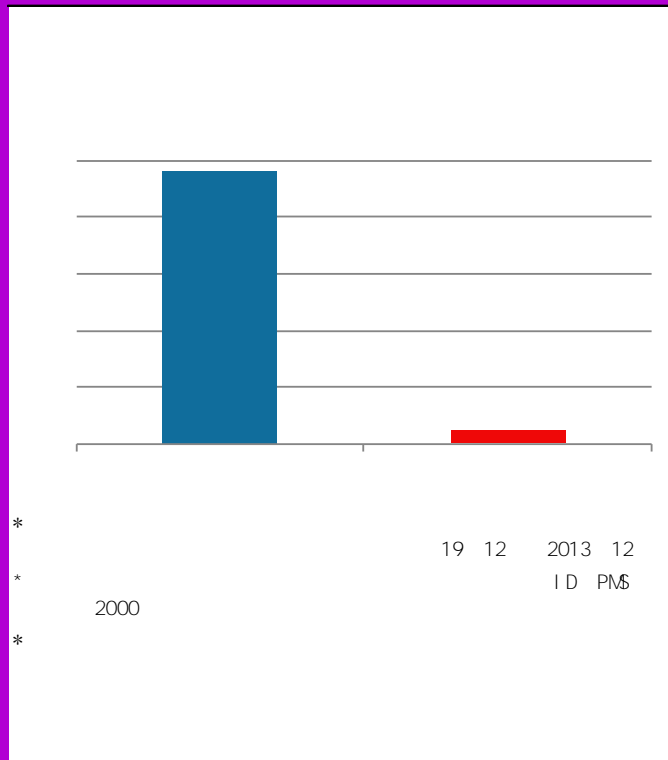

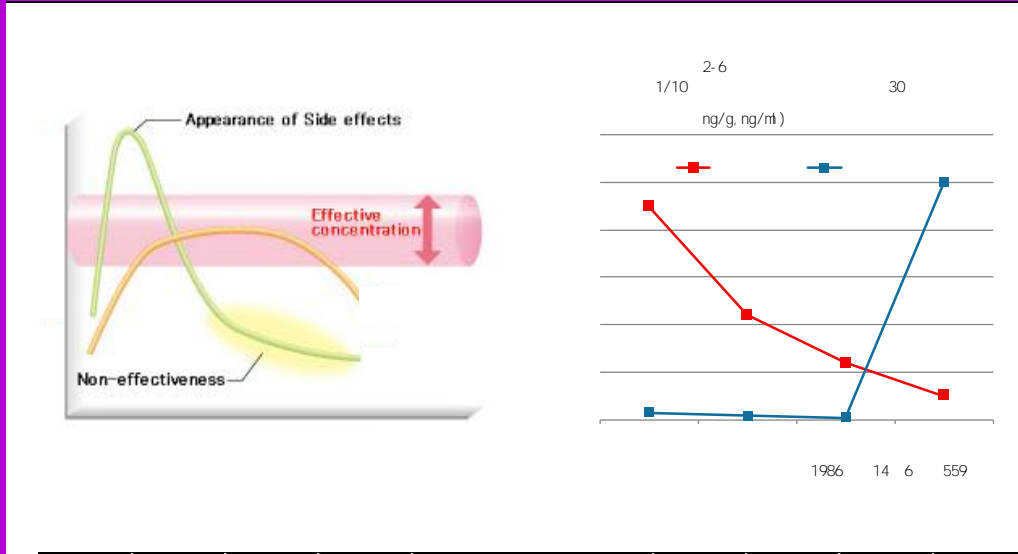

B

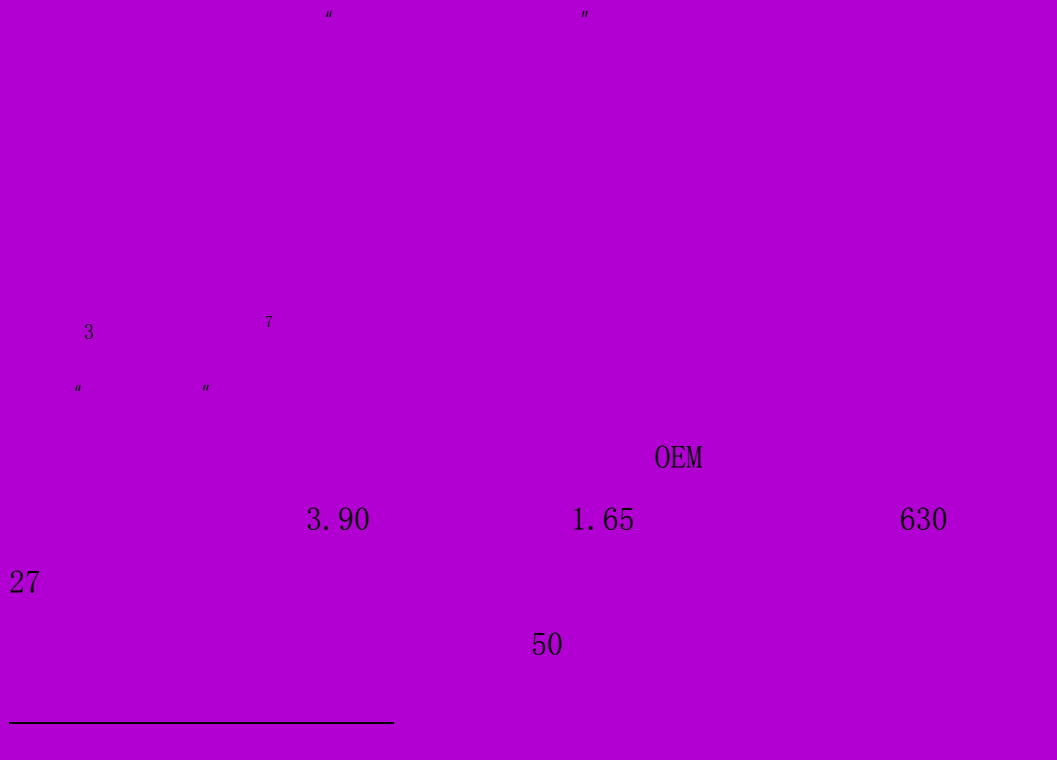

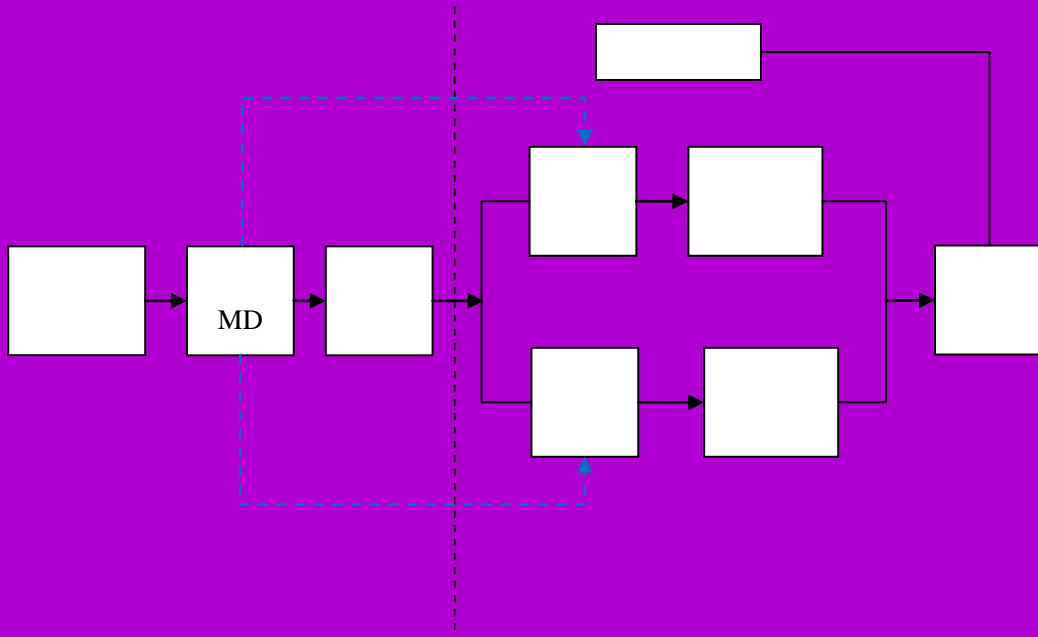

MD

"

"

"

"

2

2014

3

3

"

"

"

"

1 " "

TATSUMOTO TSUYOSHI

" "

TATSUMOTO TSUYOSHI

" " " "

" "

" "

2

500

2016 3 31

12 1 7 07 K

91110105MA004HFF3N

I

3 MDJ

MDJ

2,000

TATSUMOTO TSUYOSHI

2016 3 24

2-23-1

0110-01-110157

4

"

"

"

"

"

"

5

2016 3 6

TATSUMOTO TSUYOSHI

1

TATSUMOTO TSUYOSHI

2 " "

"

"

"

"

"

"

"

"

"

"

"

	"	"	"				
		"	"	1		"	"
	"	"	"				
		"	"	1			
	"	"	"				
		"	"	1	"	"	
3							
					"	"	
4							
"	"	2015		1,000	"	"	
	"	"		9,000			
	,						
	9,000			3,000	"	"	
"	"	6,000				60%	
MDJ60%							
5							
	"	"	3		2015	1,000	
		20%	2016-2018		1,200	1,440	
1,728							
"	"						
		"	"				
6							

10

”

”

7

8

6

6

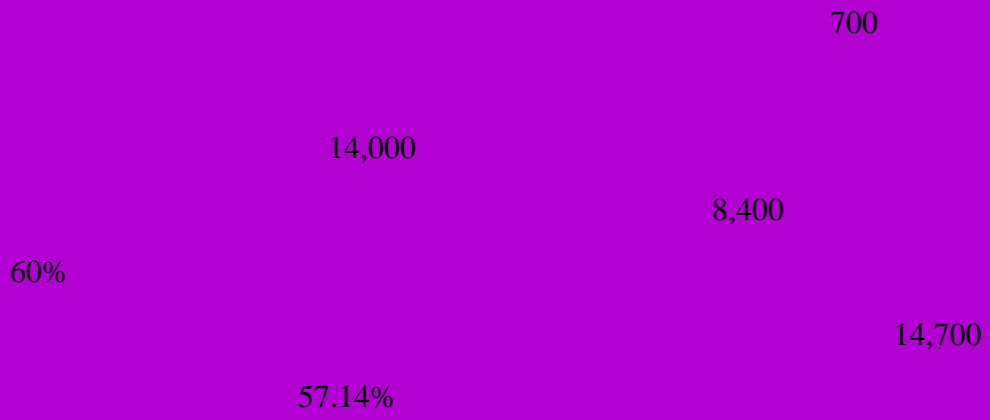

“ ”

“ ”

“ ” “ ” “ ” “ ”

“ ”

2013 12 31

2858

7,073.80

5

2 "

"

"

"

"

"

"

"

2012

2013

2014

2015

序号	事项	2015	2016	2017	2018	2019	2020
1	股权激励					25%	
2	股权激励	3,000	3,750	4,688	5,659	7,324	
3	股权激励		700				14,000
				4.76%			14,700
1	股权激励					2016	9
2	股权激励	2016					
3	股权激励			700			32,000

4

2016

2015

5

	2015	2016	
	14,000	14,000	14,700
	9,734.63	9,734.63	10,334.63
	51,919.59	61,654.22	94,254.22
/	0.87	0.70	0.73
	25.54%	0.17	0.16
2015			
	9,734.63	9,734.63	10,214.63
	51,919.59	61,654.22	94,134.22
/	0.87	0.70	0.72
	25.54%	0.17	0.16
2016 0			
	9,734.63	9,734.63	9,734.63
	51,919.59	61,654.22	93,654.22
/	0.87	0.70	0.69
	25.54%	0.17	0.15

1

9 ---

2010

2 2015

3 2016

1

“ ”

2

[2012]37

3 —

[2013]43

3

4